

MSI-8000HD

Indicator/RF Remote Display



COMPATIBLE WITH:



MSI-3460 Challenger 3



MSI-4260 Port-A-Weigh



MSI-7300 Dyna-Link 2



MSI-8000

(MSI-8000HD-2 Only)



**Measurement Systems
International™**

A RICE LAKE WEIGHING SYSTEMS COMPANY

800-874-4320
www.msiscales.com

MSI-8000HD INDICATOR/RF REMOTE DISPLAY

Rugged, Versatile Control for Overhead Weighing Operations

Fortified by the acclaimed reputation of its star precursor, MSI-8000HD is the heavy-duty version of the reputable handheld MSI-8000 RF Remote Display. The milled anodized aluminum, IP68-rated, enclosure is mountable in either a direct panel mount or optional tilt stand. The full waterproof construction resists most elements making it especially appealing to the petro-chemical, energy, marine, and aerospace industries. Fully compatible with all MSI ScaleCore-based crane scales and dynamometers, the MSI-8000HD provides utmost versatility for any application.

Fully ergonomic with user-definable function keys and a bold six-digit one inch display ease usability and readability. Process control, safety and other systems benefit with optional relays installed to optimize workflow and operator ease. The MSI-8000HD-1 and MSI-8000HD-2 may be used as a fully functional weigh meter with the standard inclusion of a precision 24-bit A/D. Additionally, the MSI-8000HD-2 has RF capability to transmit data to a secondary MSI-8000 or non-A/D MSI-8000HD.

Wi-Fi, Ethernet, or serial option cards are available for direct connections to networks and computers for advanced traceability and reporting.

Standard Features

- IP68 Rugged Milled Aluminum enclosure
- Membrane Keypad for User Control Functionality
- User Definable Function Keys for added versatility

Specifications

Enclosure:	NEMA 4/IP68 Milled anodized aluminum with O-Ring Gaskets
Keypad:	On/Off, Zero (100%), Tare, Print, and Two user-defined keys for the following functions: peak hold, high resolution, total, view total, net/gross, units switching
Display:	Six-Digit 1 in (26.4 mm) LCD
Units Displayed:	Pounds, kilograms, tons, metric tons, kilonewtons
Annunciators:	Stable, COZ, Peak, kg, kN, lb, M, Ton, Setpoint, function LEDs. Channels: 1,2,3,4 and TTL
Power Input:	90-264VAC, 9-36VDC or Internal Lithium Battery.
Internal Battery:	14° to 140° F (-10° to 60° C)
Operating Temp:	-4° to 140° F (-20° to 60° C)
RF Remote Channels:	Up to four remote sensors, monitored individually, in pairs, or sum all (non-A/D version only)
Service Counters:	A/D versions only
A/D inputs:	Two independent or Summing Load Cell inputs (MSI-8000HD-1 and MSI-8000HD-2)
Excitation:	4.8V Current Limited and over-voltage protected
Filtering:	Off, Low, Hi-1, Hi-2
Radio Link:	2.4 GHz 802.15.4 (MSI-8000HD and MSI-8000HD-2)
Radio Link Effective Range:	Typically 100 or more feet (33 m)
Data I/O:	Dual RS-232 Comm Ports

Options and Accessories

- Audible Alarm
- RS-232 Serial-output Cable with D-9 Connector, 13 ft (4 m)
- RS-232 Serial-output Cable (Unterminated), 13 ft (4 m)
- Tilt Stand
- Ethernet TCP/IP
- Relays (Consult Factory For Further Information)
- Various Antenna Types and Coax Extension Cables for Increased Range or Remote Mounting the Antenna.

Dimensions

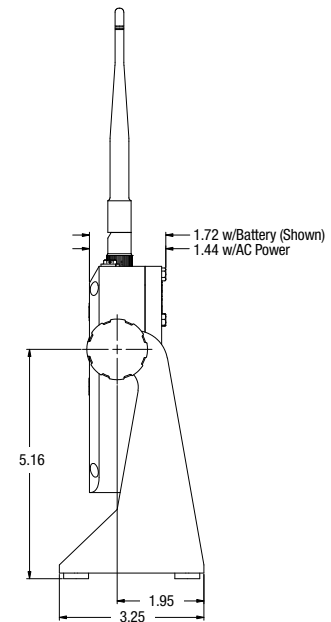
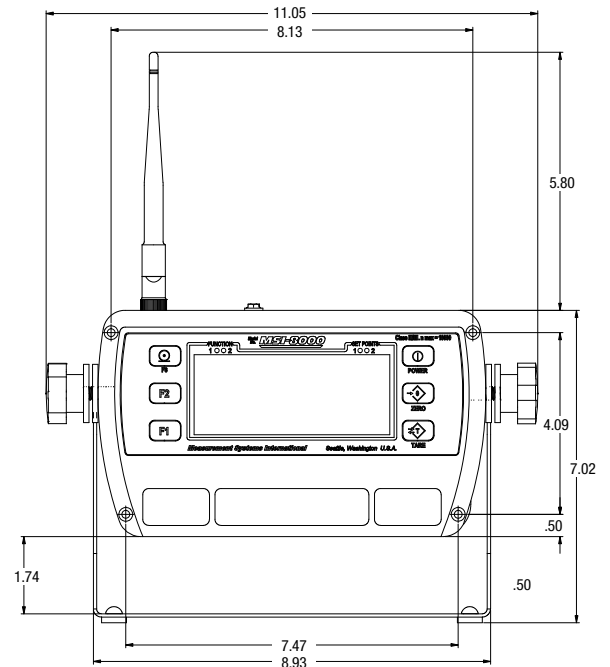

14240 Interurban Avenue South, STE. 200, Seattle, Washington 98168-4661 USA
TEL: 206-433-0199 • FAX: 206-244-8470 • EMAIL: info@msiscales.com www.msiscales.com

© 2014 by Measurement Systems International, Inc PN 158651 9/14
Specifications subject to change without notice. Printed in USA