

# MSI-4260M

PORT-A-WEIGH INDUSTRIAL CRANE SCALE

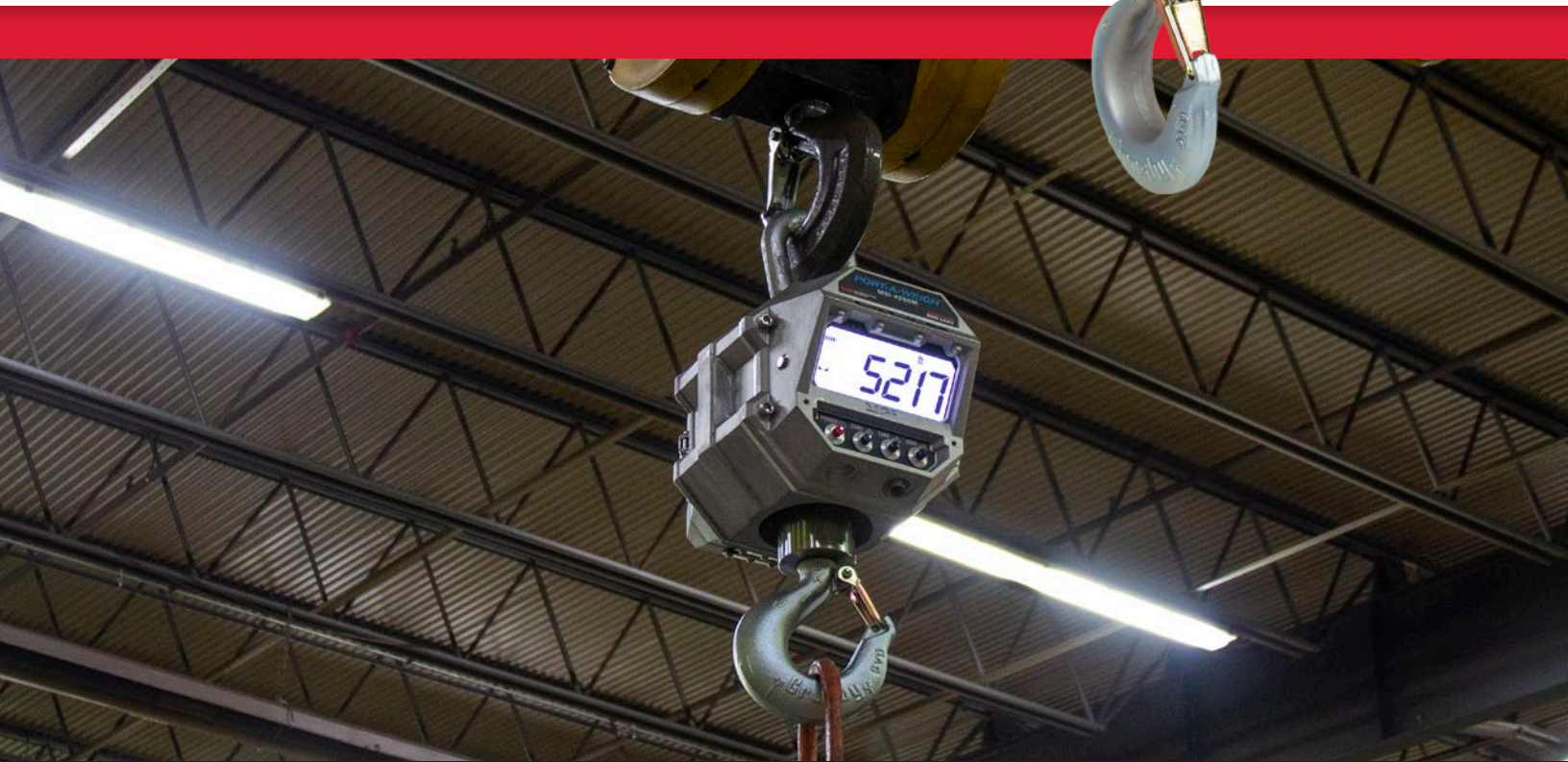

**RICE LAKE**<sup>®</sup>  
WEIGHING SYSTEMS

800-472-6703

[www.ricelake.com](http://www.ricelake.com)

# MSI-4260M

PORT-A-WEIGH INDUSTRIAL CRANE SCALE



For medium- to heavy-capacity needs, the MSI-4260M has an established reputation as the industry standard in overhead weighing. The MSI-4260M Port-a-Weigh crane scale captures weight with  $\pm 0.1\%$  accuracy through its full range of capacity starting at 500 pounds up to 100,000 pounds.

The MSI-4260M is built to perform reliably and offers two standard battery options: six (6) D-Cell batteries or a 12V sealed lead acid (SLA) battery. Timed auto-off and auto-sleep modes conserve power when the unit is not in use, meaning it is always ready for the job.

With an IP66 aluminum enclosure, it keeps dust out and withstands high-pressure water. Sensitive electronic components are sealed off and well-protected, including the MSI-4260M's sleek and vibrant LCD display. Featuring programmable brightness control, the display ensures users have access to the weight data they need in any light condition.

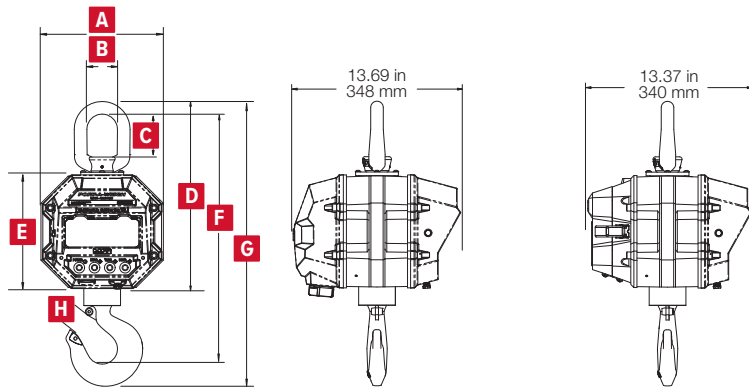

FRONT VIEW      SIDE VIEW D-CELL      SIDE VIEW 12V

## STANDARD FEATURES

- LCD display
- IP66 cast aluminum
- Top lifting eye or shackle, bottom thrust bearing swivel hook
- Battery operated, six (6) D cell 1.5V alkaline batteries or 12 volt rechargeable battery (115/230 VAC battery charger is included)
- NTEP Certified configuration

## OPTIONS

- Rugged remote control (control for On/Off, Zero, Tare and other functions)
- RF modem install for connectivity to MSI-8000, MSI-8000HD RF, MSI-8004HD RF remote display, TranSend and LaserLight2 remote display
- Wi-Fi communication is available for specialty applications
- Anti-heat shielding for high temperature applications
- Substitute bottom swivel hook with shackle
- Oversized top lifting eye or shackle
- Oversized bottom hook
- Universal direct power supply; 85 to 265 VAC, 47 to 440 Hz / 130 to 300 VDC
- Low headroom top adapter
- Audible alarm

## SPECIFICATIONS

<b>ACCURACY:</b>	$\pm 0.1\%$ $\pm 1$ d of applied load
<b>RESOLUTION:</b>	Max NTEP Approved Class III: 2,500 d Max NTEP Approved Class IIII: 5,000 d Max Non NTEP Approved: 10,000 d
<b>ENCLOSURE:</b>	IP66 cast aluminum
<b>LIFTING EYE, SHACKLE &amp; HOOK:</b>	Crosby® or equal with 360° thrust-bearing swivel hook
<b>DESIGN OVERLOAD:</b>	200% Safe / 500% Ultimate (except where noted)
<b>FUNCTIONS:</b>	Power: Turns unit on or off Zero: Zeros applied load up to 100% of capacity (limited range in NTEP configurations) Tare: Tares applied load and displays weight in Net mode User: Programmable as test, total, unit, peak hold, net/gross, view total and print
<b>DISPLAY:</b>	Five-digit, 1.75 in (44.5 mm) LCD with programmable brightness control
<b>DISPLAYABLE UNITS:</b>	Pounds or kilograms selectable
<b>ANNUNCIATORS:</b>	COZ, Battery Level, Net, Total, lb/kg, Stability, RF and Setpoint LEDs
<b>POWER:</b>	Battery operated, six (6) D cell 1.5V alkaline batteries or 12 volt rechargeable battery (115/230 VAC battery charger is included)
<b>OPERATING TIME:</b>	Six (6) D Cell 1.5V alkaline batteries: Up to 1,000 hours of battery life with typical use, less with RF modem 12 volt rechargeable battery: Up to 250 hours between charging with typical use, less with RF modem.
<b>TEMPERATURE RANGE:</b>	Operating: -20 °F to 122 °F (-20 °C to 50 °C) Certified: 14 °F to 104 °F (-10 °C to 40 °C)
<b>AUTO-OFF MODE:</b>	Powers off after the scale is not used for the set time (in minutes); 15, 30, 45, 60 or OFF selectable
<b>AUTO SLEEP MODE:</b>	Powers down during non-use after the set time (in minutes) and powers up with weight change or any key press; 5, 15, 30 or OFF selectable
<b>SERVICE COUNTERS:</b>	Counts number of lifts over percentage of capacity and lifts over capacity
<b>CALIBRATION:</b>	Digital (procedure initiated by calibration switch)
<b>FILTERING:</b>	OFF, LO, HI-1 or HI-2 selectable
<b>RADIO LINK:</b>	802.15.4 at 2.4 GHz
<b>RADIO EFFECTIVE RANGE:</b>	Typically 100 to 300 ft line of sight
<b>WARRANTY:</b>	One-year limited

Capacity	Resolution	A	B	C	D	E	F	G	H	Safety Factor	Est. Ship Weight
500 lb / 250 kg	0.2 lb / 0.1 kg	10 in	2.25 in	3.06 in	14.49 in	9.28 in	18.9 in	21.26 in	1.5 in	>5	53 lb
2,000 lb / 1,000 kg	1.0 lb / 0.5 kg	254 mm	57 mm	78 mm	368 mm	236 mm	480 mm	540 mm	38 mm		24 kg
5,000 lb / 2,500 kg	1.0 lb / 0.5 kg	10 in	2.50 in	3.5 in	15.28 in	9.28 in	20.5 in	23.25 in	1.78 in	>5	62 lb
10,000 lb / 5,000 kg	2.0 lb / 1.0 kg	254 mm	64 mm	89 mm	388 mm	236 mm	521 mm	591 mm	45 mm		28 kg
20,000 lb / 10,000 kg	5.0 lb / 2.0 kg	10 in	4.10 in	6.11 in	19.13 in	9.28 in	28.4 in	32.58 in	2.62 in	>7	105 lb
30,000 lb / 15,000 kg	10.0 lb / 5.0 kg	254 mm	104 mm	155 mm	486 mm	236 mm	721 mm	828 mm	67 mm	>6.5	47 kg
50,000 lb / 25,000 kg	10.0 lb / 5.0 kg	10 in	5 in	6 in	22.35 in	9.40 in	41.7 in	46.98 in	4 in	>5	235 lb
70,000 lb / 35,000 kg	20.0 lb / 10.0 kg	254 mm	127 mm	152 mm	568 mm	239 mm	1059 mm	1193 mm	102 mm	4.9*	106 kg
100,000 lb / 50,000 kg	20.0 lb / 10.0 kg	10 in	5.75 in	6.67 in	23.62 in	9.40 in	43.9 in	50.15 in	4.25 in	4.75**	270 lb
		254 mm	146 mm	169 mm	600 mm	239 mm	1115 mm	1274 mm	108 mm	4.3**	420 kg
		10 in	5.75 in	6.67 in	23.62 in	9.40 in	51.3 in	58.36 in	4.75 in	4.5***	420 lb
		254 mm	146 mm	169 mm	600 mm	239 mm	1303 mm	1482 mm	121 mm	4***	189 kg

\*Ultimate overload: 490% of kg capacity  
\*\*Ultimate overload: 475% of lb capacity / 430% of kg capacity  
\*\*\*Ultimate overload: 450% of kg capacity



**RICE LAKE**  
WEIGHING SYSTEMS

**HEADQUARTERS**  
230 West Coleman Street  
Rice Lake, Wisconsin 54868 - USA  
Tel: (715) 234 9171 | Fax: (715) 234 6967  
[www.ricelake.com](http://www.ricelake.com)